



RPCE3-*

PROPORTIONAL FLOW CONTROL VALVE, PILOT OPERATED

SERIES 52

RPCE3-*/C two-port
RPCE3-100-T3 three-port

SUBPLATE MOUNTING
ISO 6263-07

p max 250 bar
Q max (see performances table)

OPERATING PRINCIPLE

RPCE3-*/C

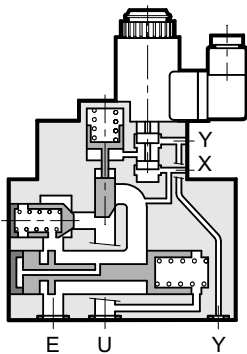

RPCE3-100-T3

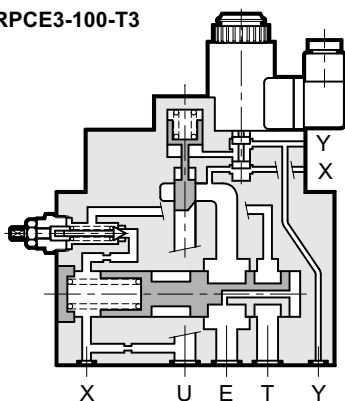

- RPCE3 valves are proportional flow control valves pressure- and temperature-compensated, with two-ports or three-ports, with mounting interface in compliance with ISO 6263 standards.
- These valves are employed for flow rate control in hydraulic circuit branches and for speed control of hydraulic actuators.
- Flow rate can be modulated continuously in proportion to the current supplied to the solenoid.
- The valve can be controlled directly by a current control supply unit or combined with an external electronic card to maximize the valve performances (see par. 10).
- The valves are available in three flow control ranges: two with progressive gain up to 72 l/min and the third with differential gain of 30 l/min.
- The minimum pilot flow rate required to operate correctly is 2 l/min, with a minimum pressure of 20 bar.
- Pilot signal can be internal, flowing through port E in the mounting surface, or coming from an external pilot line with 1/4" BSP connection to the X port placed on valve side. If internal pilot is chosen this X port comes plugged.
- Drainage is always external and must be connected directly to the tank without backpressure flowing from Y port in the mounting surface (OR Ø32) or from Y port on valve side by a drain line (1/4" BSP connection).
- The three-port version RPCE3-100-T3 allows controlled flow in working line U, dumping the residual flow to the tank. The maximum pressure from the circuit is limited by means of an adjustable relief valve which operates on the compensator pilot.

HYDRAULIC SYMBOLS

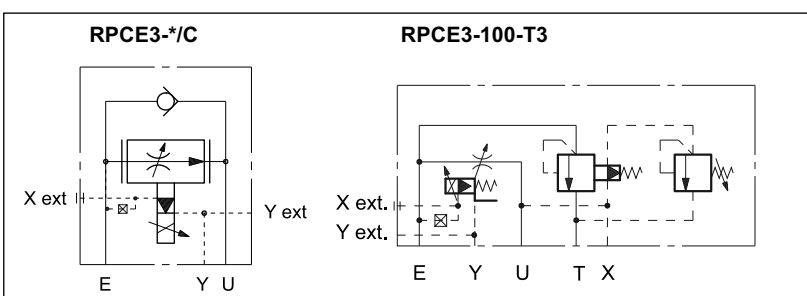



1 - IDENTIFICATION CODES

1.1 - Identification code for two-port valve: RPCE3-*/C

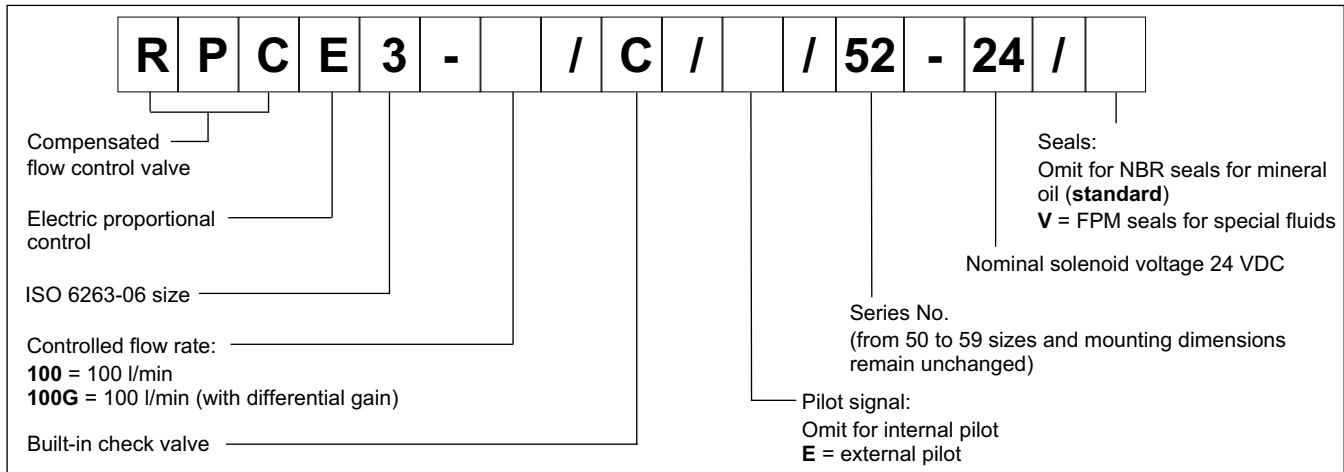

1.2 - Identification code for three-port valve: RPCE2-70-T3

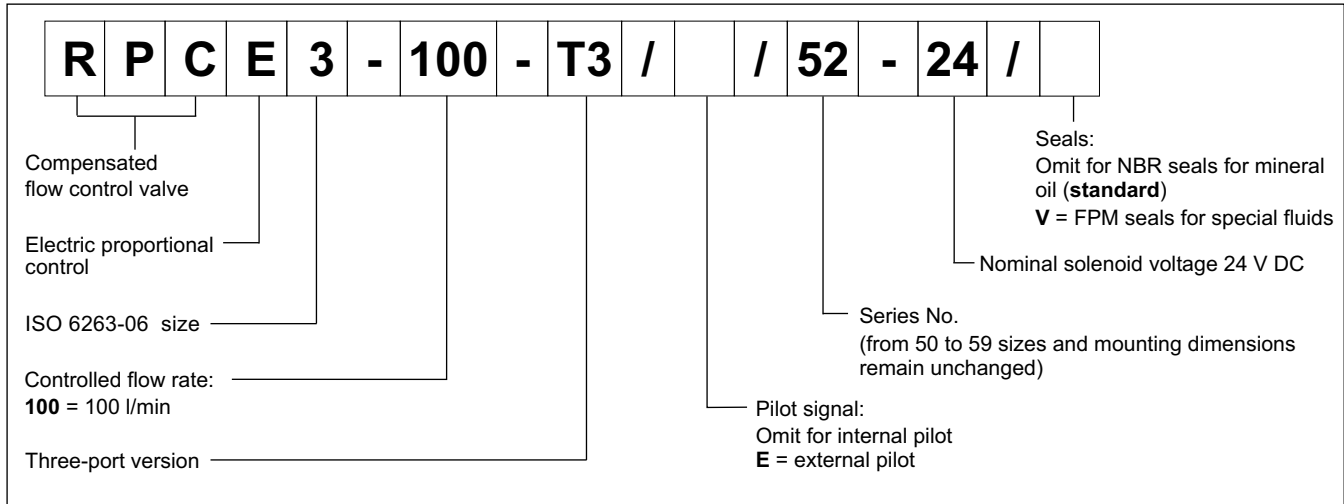

2 - PERFORMANCES (obtained with mineral oil with viscosity of 36 cSt at 50°C and electronic control card)

Maximum working pressure	bar	250
Minimum Δp across E and U ports		10
Piloting pressures:		20
min		160 (NOTE 1)
max		
Maximum controlled flow E→U (RPCE3-*)	l/min	100
Minimum controlled flow with P=100 bar (version 100)		1,5
(version 100G)		0,5
Maximum free reverse flow U→E		150 (NOTE 2)
Step response	see paragraph 8	
Hysteresis (with PWM 100 Hz)	% of Q _{max}	< 8%
Repeatability	% of Q _{max}	< ±3%
Electrical features	see paragraph 7	
Ambient temperature range	°C	-10 / +60
Fluid temperature range	°C	-20 / +80
Fluid viscosity range	cSt	10 ÷ 400
Fluid contamination degree	According to ISO 4406:1999 class 18/16/13	
Recommended viscosity	cSt	25
Mass	kg	10,3

NOTE 1: Pilot must be external if the valve had to operate with pressure line over 160 bar.

NOTE 2: Maximum recommended flow U→E through the check valve (only for two-port version).

3 - HYDRAULIC FLUIDS

Use mineral oil-based hydraulic fluids HL or HM type, according to ISO 6743-4. For these fluids, use NBR seals. For fluids HFDR type (phosphate esters) use FPM seals (code V). For the use of other kinds of fluid such as HFA, HFB, HFC, please consult our technical department. Using fluids at temperatures higher than 80 °C causes a faster degradation of the fluid and of the seals characteristics.

The fluid must be preserved in its physical and chemical characteristics.

4 - CHARACTERISTIC CURVES

(measured with viscosity of 36 cSt at 50°C)

4.1 - 2-way valve

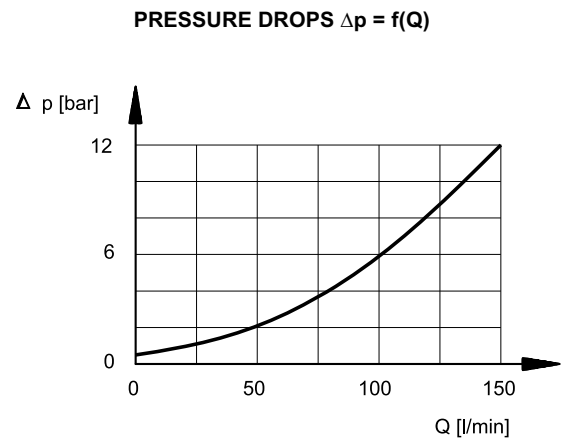
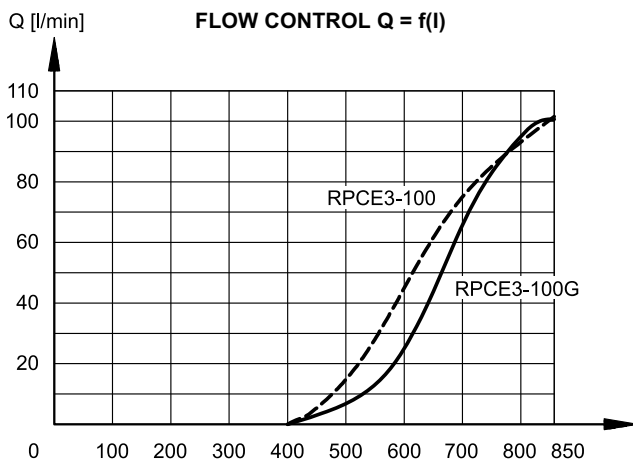

Typical flow control curves for flow rate E→U, according to the current supplied to the solenoid.

The RPCE3-100G version, featuring differential gain control, is particularly suitable for “FAST-SLOW” flow rate control as it ensures high sensitivity at low flow rate control while enabling high flow rates for rapid actuator movement.

Pressure drops with free flow U→E through the check valve.

4.1 - 3-way valve

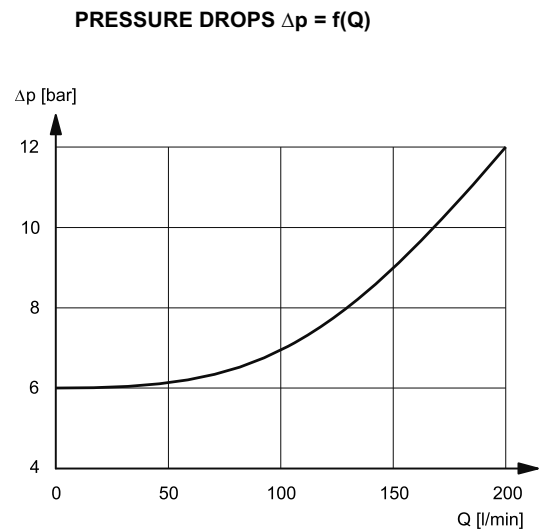
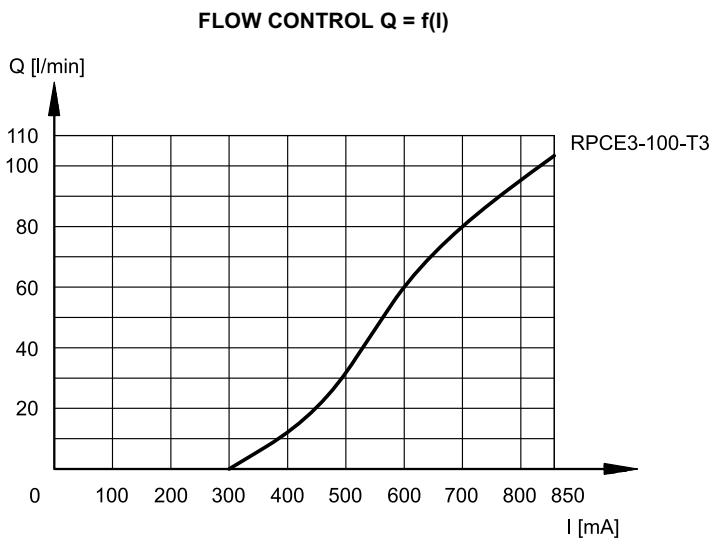

Typical flow control curves for flow rate E→U, according to the current supplied to the solenoid.

Pressure drops E→T

5 - PRESSURE COMPENSATION

The valves are equipped with two restrictors. The first is an opening which can be adjusted by the proportional solenoid; the second, controlled by the pressure upstream and downstream of the first restrictor ensures constant pressure drop across the adjustable restrictor.

In these conditions, the set flow rate value is maintained constant within a tolerance range of $\pm 3\%$ of the set flow rate for maximum pressure variation between the valve inlet and outlet chambers.

6 - THERMAL COMPENSATION

A temperature-sensitive device installed on the flow control element corrects the position and maintains the set flow rate virtually unchanged, also in the case of fluid viscosity variation.

Flow rate variation remains within 2,5% of the set flow rate, for a fluid temperature variation of 10°C.

7 - ELECTRICAL CHARACTERISTICS

Proportional solenoid

The proportional solenoid comprises two parts: tube and coil.

The tube, screwed to the valve body, contains the armature which is designed to maintain friction to a minimum thereby reducing hysteresis.

The coil is mounted on the tube secured by means of a lock nut and can be rotated through 360° depending on installation clearances.

NOMINAL VOLTAGE	V DC	24
RESISTANCE (AT 20°C)	Ω	16.6
MAXIMUM CURRENT	A	0.85
ELECTROMAGNETIC COMPATIBILITY (EMC)	According to 2014/30/EU	
CLASS OF PROTECTION Atmospheric agents (IEC EN 60529)	IP 65	

8 - STEP RESPONSE

(obtained with mineral oil with viscosity of 36 cSt at 50°C and electronic control card)

Step response is the time taken for the valve to reach 90% of the set pressure value following a step change of reference signal.

REFERENCE SIGNAL STEP	0 → 100%	100 → 0%
Step response [ms]	250	120

9 - INSTALLATION

The RPCE3 valves, both two-port or three-port versions, can be installed in any position without impairing correct operation. Ensure that there is no air in the hydraulic circuit.

Valves are fixed by means of screws or tie rods on a flat surface with planarity and roughness equal to or better than those indicated in the relative symbols. If minimum values are not observed fluid can easily leak between the valve and support surface.

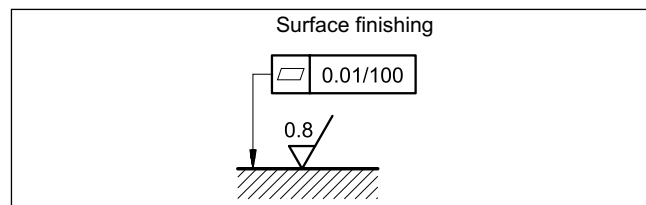

10 - ELECTRONIC CONTROL UNITS

EDC-111	plug version	see cat. 89 120
EDM-M111	DIN EN 50022 rail mounting	see cat. 89 251

11 - RPCE3-100-T3 - OVERALL AND MOUNTING DIMENSIONS

dimensions in mm

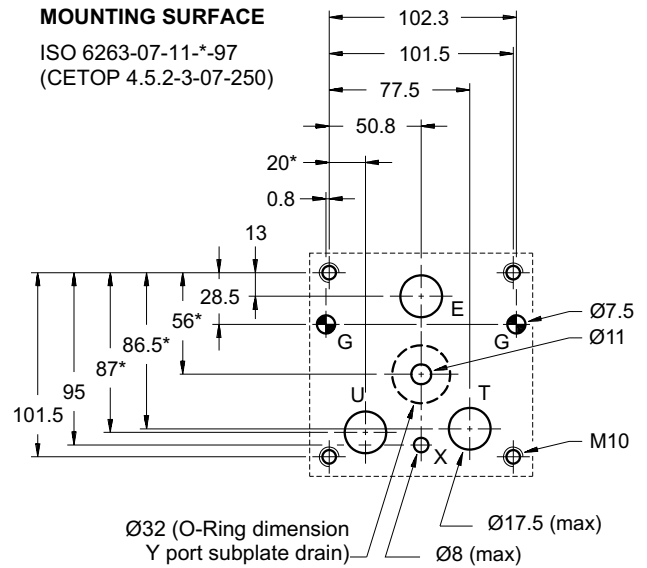
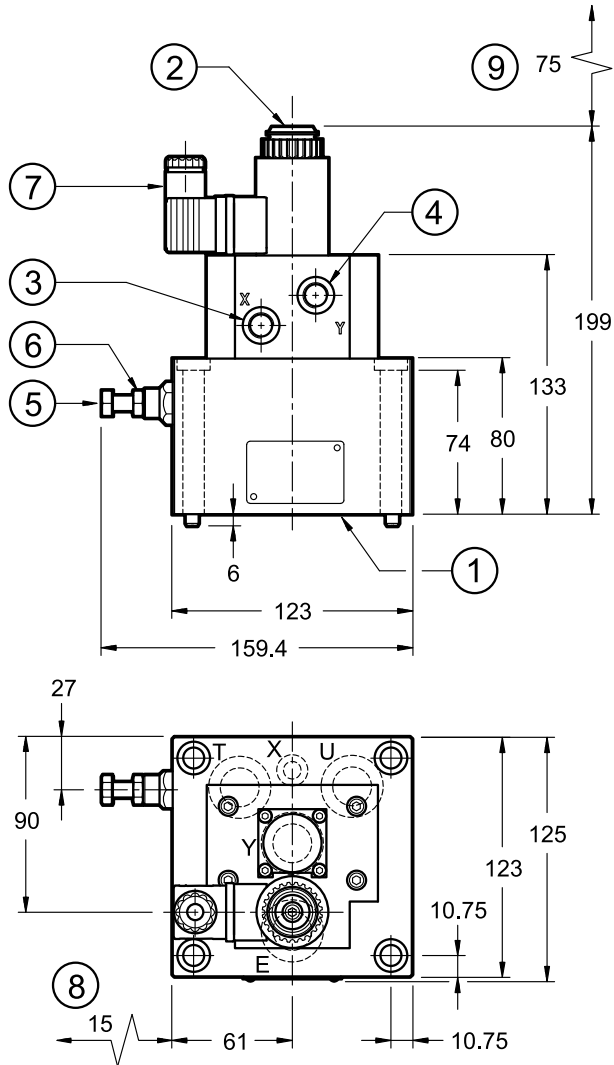

NOTE: Dimensions with the asterisk * deviate from ISO standard.

Valve fastening: 4 SHC screws ISO 4762 M10x90
Tightening torque: 40 Nm (A8.8)
Threads of mounting holes: M10x15

1	Mounting surface with sealing rings: N. 3 OR type 3106 (26.65x2.62) N. 1 OR type 2112 (28.30x1.78) N. 1 OR type 3043 (10.78x2.62)
2	Breather (Allen key 4)
3	External pilot port X: 1/4" BSP. (plugged if internal pilot is chosen)
4	Drain port Y: 1/4" BSP if port Y in mounting surface is not used
5	Pressure relief valve: Adjustment screw: spanner 13 Turn clockwise to increase pressure. P max 210 bar
6	Locking ring: spanner 13
7	EN 175301-803 (ex DIN 43650) electric connector
8	Connector removal space
9	Coil removal space

12 - OVERALL AND MOUNTING DIMENSIONS TWO-PORT VALVE RPCE3-*/C

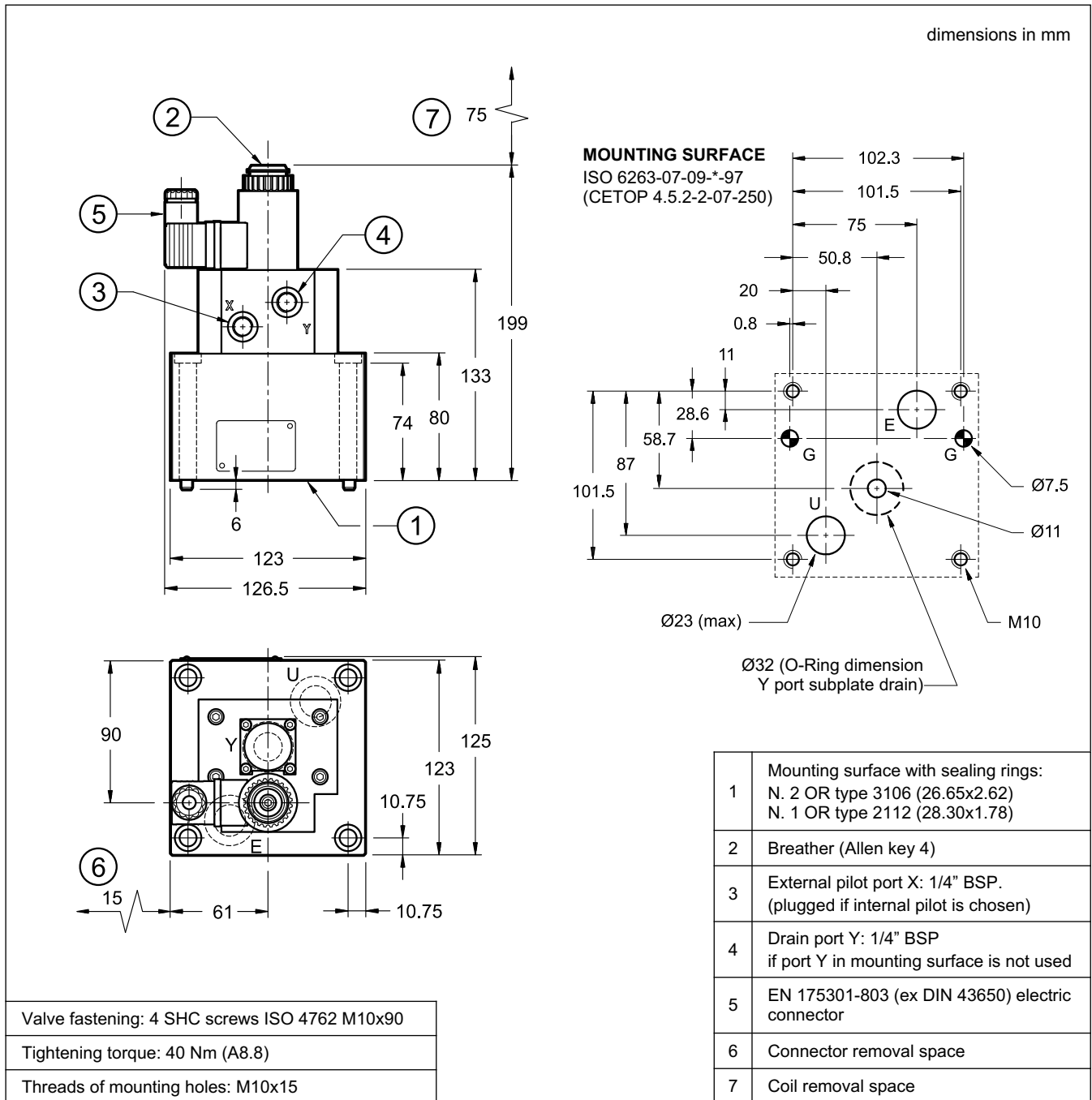

13 - SUBPLATES

(see catalogue 51 000)

Subplates listed below are suitable only for valves with Y drain with external pipe.

	RPCE3-*/C two way version	RPCE3-*/-T3 three way version
Type	PMRPC3-AI6G rear ports	PMRPCQ3-AI6G rear ports
E, U, T ports threading	1" BSP	1" BSP
X port threading	-	1/4" BSP